

4

3

2

1

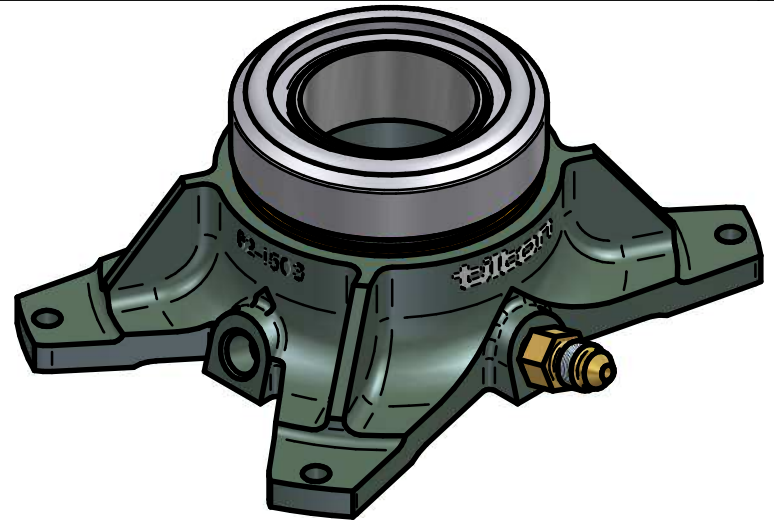

- INSTALLATION NOTES:**
1. USE ONLY WITH DOT-3 OR DOT-4 BRAKE FLUID.
  2. NO INTERNAL TRAVEL LIMITER. MUST BE USED WITH CLUTCH PEDAL STOP.
  3. SEAL REBUILD KIT = 62-905.
  4. SEAL INSTALLATION TOOL = 96-002.
  5. HYDRAULIC AREA = 1.215 SQ IN.
  6. EITHER PORT MAY BE USED FOR FEED OR BLEED.
  7. ORIENTATE BLEED PORT TO WITHIN 10 DEGREES OF TOP CENTER TO FACILITATE BLEEDING PROCESS.
  8. BOTH PORTS 3/8-24 UNF X .28 THREAD DEPTH.

| ITEM | PART NUMBER | DESCRIPTION    | QTY |
|------|-------------|----------------|-----|
| 1    | 62-1503     | HYDRAULIC BASE | 1   |
| 2    | 62-617      | WIPER          | 1   |
| 3    | 62-614      | HYDRAULIC SEAL | 1   |
| 4    | 73-820      | FITTING, AN-3  | 2   |
| 5    | 62-612      | PISTON         | 1   |
| 6    | 62-002      | BEARING        | 1   |

\*This document contains proprietary information of TILTON ENGINEERING, INC., and its receipt or possession does not convey the rights to reproduce, disclose its contents, or to manufacture, use or sell anything it may describe. Reproduction, disclosure, or use without specific written authorization of TILTON ENGINEERING, INC. is strictly forbidden.\*

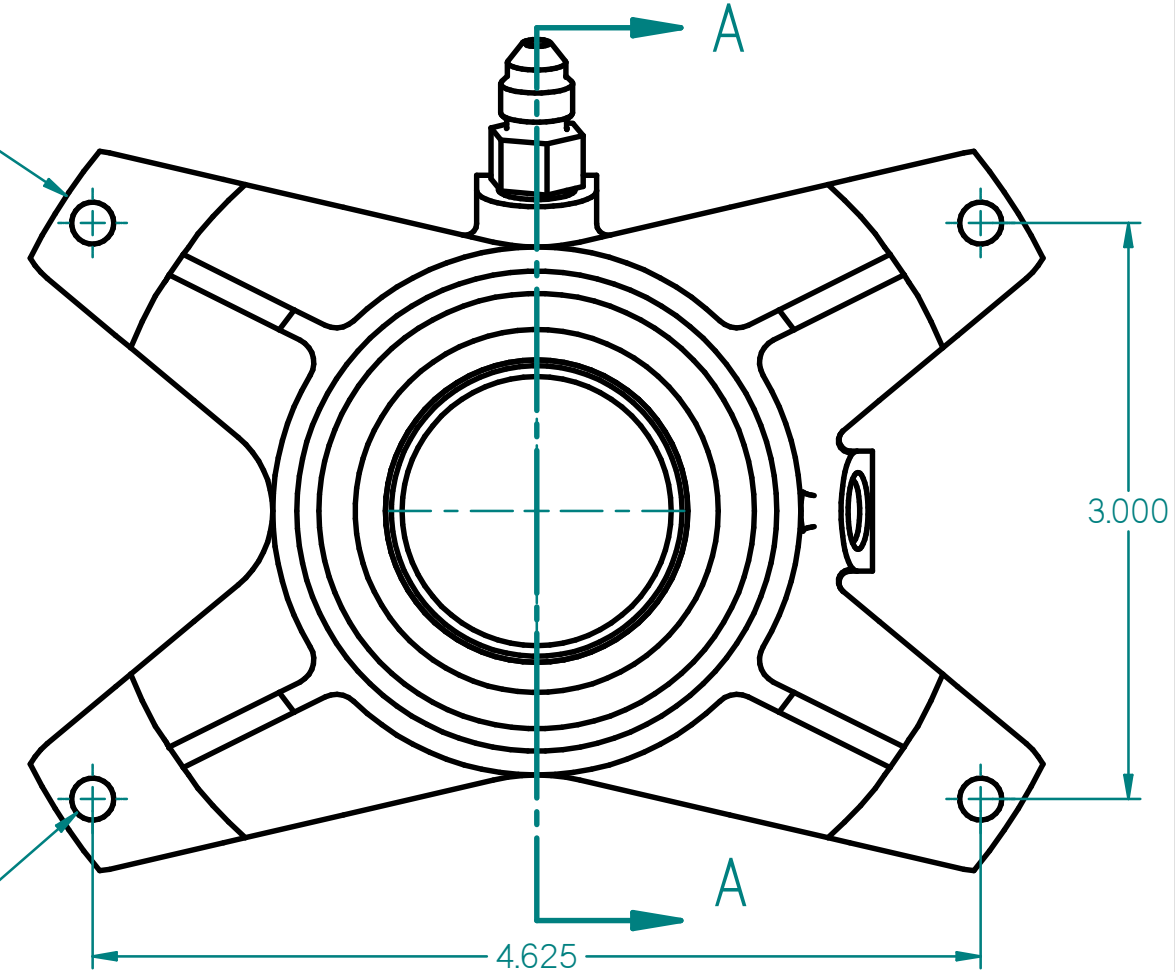
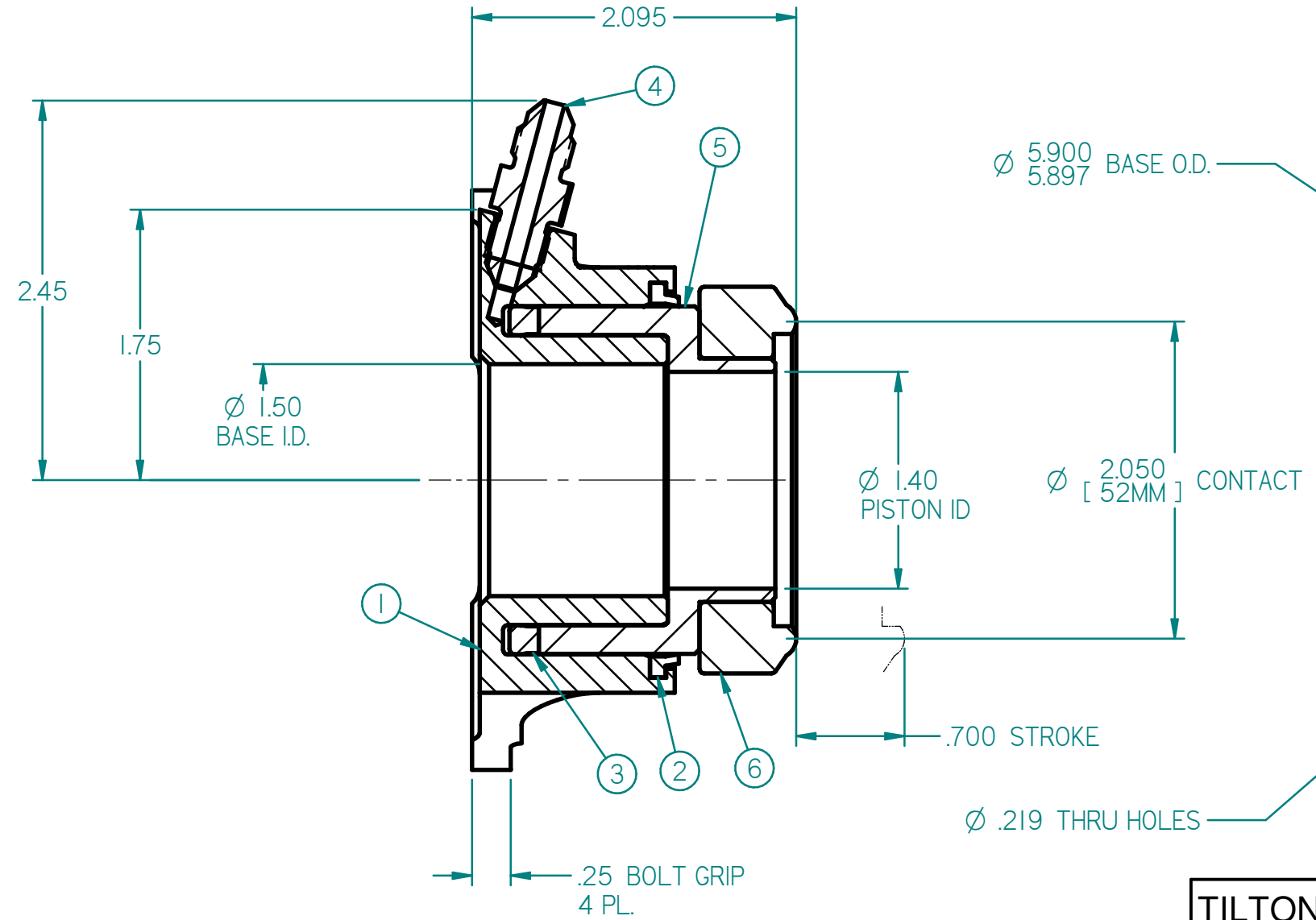

SECTION A-A

|   |                 |                  |          |
|---|-----------------|------------------|----------|
| TILTON ENGINEERING, INC.  |                 | FAX 805/688-2745 |          |
| 25 EASY STREET, P.O. BOX 1787, BUELLTON, CA 93427 805/688-2353  |                 |                  |          |
| TITLE: <b>HYDRAULIC RELEASE BEARING ASSEMBLY</b><br><b>52 mm RADIUS FACED BEARING, TILTON BELLHOUSING MOUNT</b> |                 |                  |          |
| DRAWN BY WAHL   | CHKD            | SCALE 1:1        | SIZE B   |
| P/N 60-5000   | DATE 12/30/2019 | SHEET 1 OF 1     | DWG 7263 |
|   |                 |                  | REV NC   |

**TILTON ENGINEERING, INC.**