

ITEM	PART NUMBER	DESCRIPTION	QTY
1	62-617	WIPER	1
2	62-614	HYDRAULIC SEAL	1
3	62-521	SWIVEL HOSE, AN-4	2
4	62-714	HYDRAULIC BASE	1
5	62-618	BEARING	1
6	SEE CHART	SLEEVE	1
7	62-6100	PISTON	1
8	5100-43	SNAP RING	2
9	SEE CHART	ANTI-ROTATION STUD	1

THREADED MOUNTING SLEEVE CHART			
SLEEVE P/N	SLEEVE I.D.	USED IN ASS'Y P/N	O-RING PN
62-651	1.438	60-6102, 60-6104	61-627-1
62-652	1.375	60-6101, 60-6103	61-628-1
62-653	1.000*	60-6100	N/A

\*MAY BE MACHINED TO MATCH O.D. OF TRANSMISSION PILOT TUBE. DO NOT EXCEED 1.450" DIAMETER.

ANTI-ROTATION STUD CHART		
STUD P/N	STUD THREAD	USED IN ASS'Y P/N
95-603	5/16"-18 UNC	60-6101, 60-6102
95-604	M8 X 1.25	60-6103, 60-6104

STUD NOT INCLUDED IN 60-6100 "UNIVERSAL" ASSEMBLY.

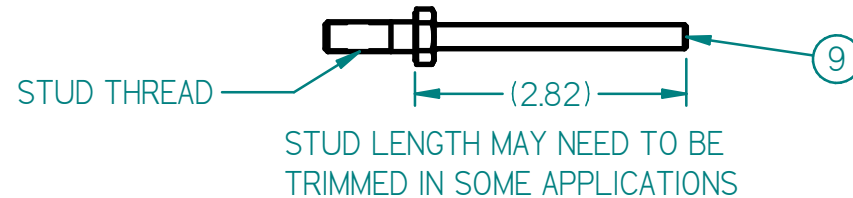
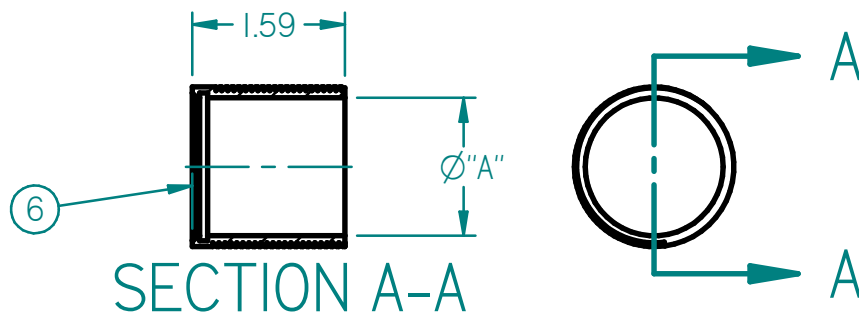

**INSTALLATION NOTES:**

1. USE ONLY WITH DOT-3 OR DOT-4 BRAKE FLUID.
2. NO INTERNAL TRAVEL LIMITER. MUST BE USED WITH CLUTCH PEDAL STOP.
3. SEAL REBUILD KIT = 62-905.
4. SEAL INSTALLATION TOOL = 96-002.
5. HYDRAULIC AREA = 1.215 SQ IN.
6. EITHER PORT MAY BE USED FOR FEED OR BLEED.
7. ORIENTATE BLEED PORT TO WITHIN 10 DEGREES OF TOP CENTER TO FACILITATE BLEEDING PROCESS.

TILTON ENGINEERING, INC.		FAX 805/688-2745	
25 EASY STREET, P.O. BOX 1787, BUELLTON, CA 93427 805/688-2353			
<b>TITLE: HYDRAULIC RELEASE BEARING ASSEMBLY FLAT FACED BEARING, 6000 SERIES, THREADED SLEEVE MOUNTED</b>			
DRAWN BY LUND	CHKD WAHL	SCALE 1:2	SIZE DWG
P/N SEE CHART	DATE 10/23/13	SHEET 1 OF 1	B 5909
			REV D

\*This document contains proprietary information of TILTON ENGINEERING, INC., and its receipt or possession does not convey the rights to reproduce, disclose its contents, or to manufacture, use or sell anything it may describe. Reproduction, disclosure, or use without specific written authorization of TILTON ENGINEERING INC. is strictly forbidden.

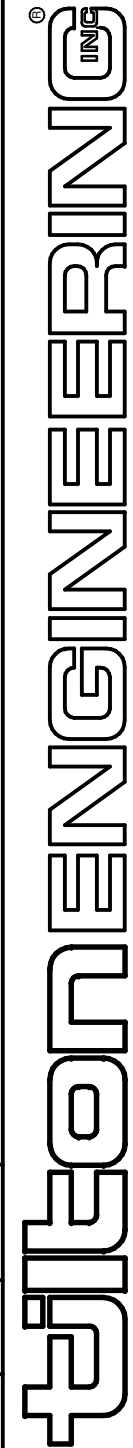

REV	ECN	DATE	BY	CHANGE OR ADDITION
-----	-----	------	----	--------------------

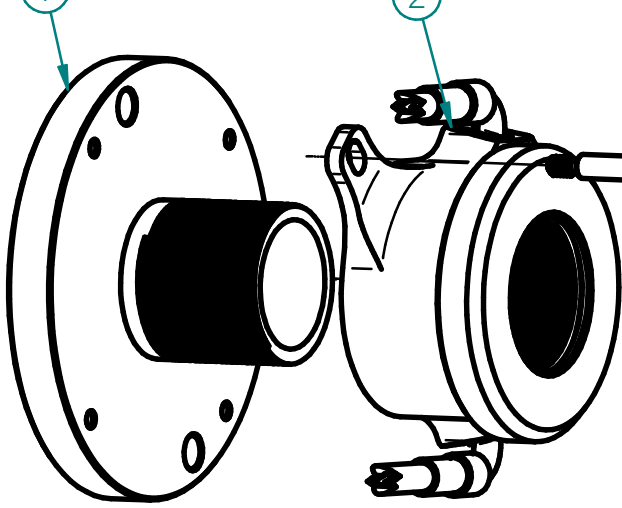
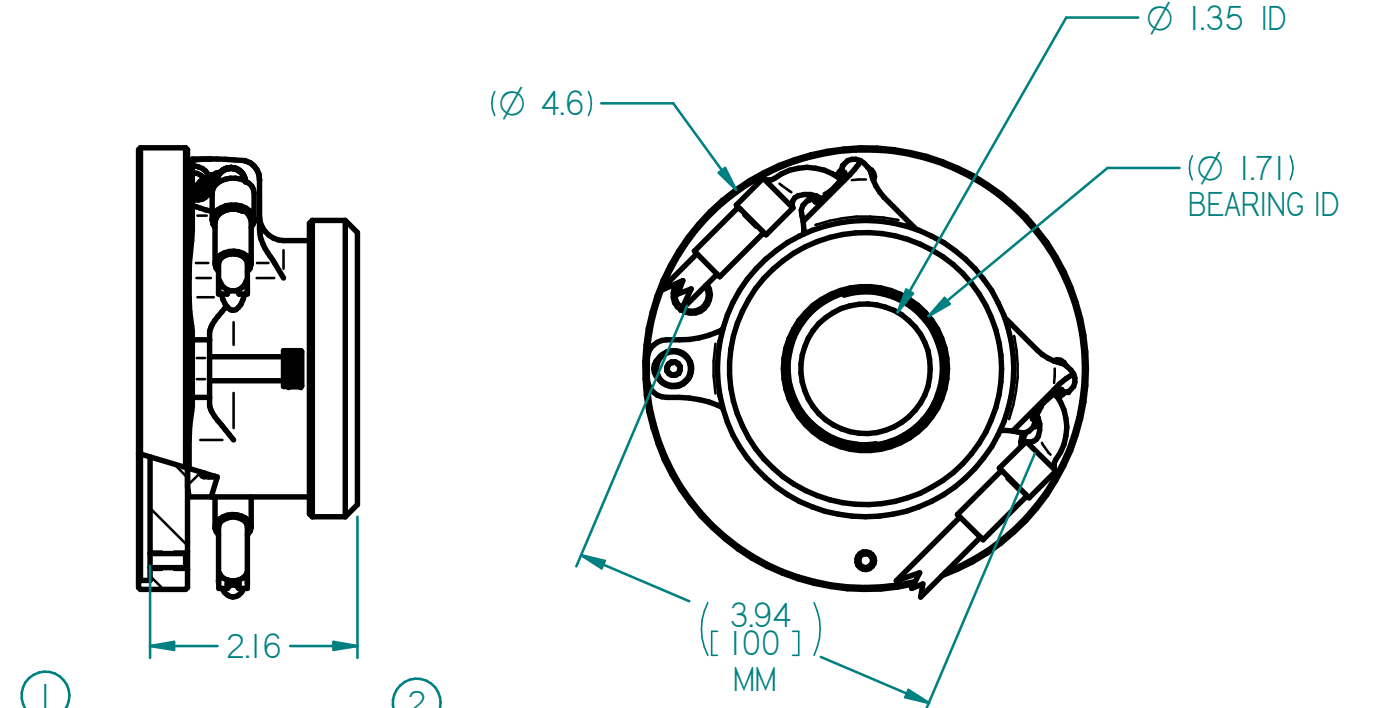

ITEM #	PART #	DESCRIPTION	QTY
1	62-899	ASSY,ADAPTER,T56 CHEV/FORD/MOPAR, 6000 SERIES HRB	1
2	60-610	HYDR REL BRG, FLAT FACE	1
3	1/4 X 1 SB	SHOULDER BOLT	1

- NOTES:**
1. DIMENSIONS AND TOLERANCES PER ASME Y14.5 - 2009
  2. UNLESS OTHERWISE SPECIFIED, ALL DIMENSIONS ARE IN INCHES.
  3. BOTH SHOULDER BOLT LENGTHS ARE INCLUDED WITH 62-899 ASSEMBLY.
  4. USE ONLY WITH DOT-3 OR DOT-4 BRAKE FLUID.
  5. NO INTERNAL TRAVEL LIMITER. MUST BE USED WITH CLUTCH PEDAL STOP.
  6. SEAL REBUILD KIT = 62-905.
  7. SEAL INSTALLATION TOOL = 96-002.
  8. HYDRAULIC AREA = 1.215 SQ IN.
  9. EITHER PORT MAY BE USED FOR FEED OR BLEED.
  10. ORIENTATE BLEED PORT TO WITHIN 10 DEGREES OF TOP CENTER TO FACILITATE BLEEDING PROCESS.

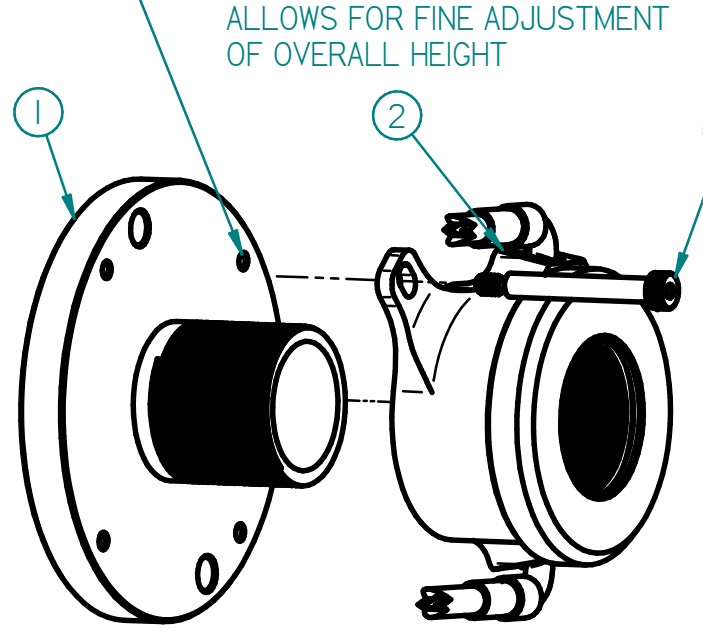
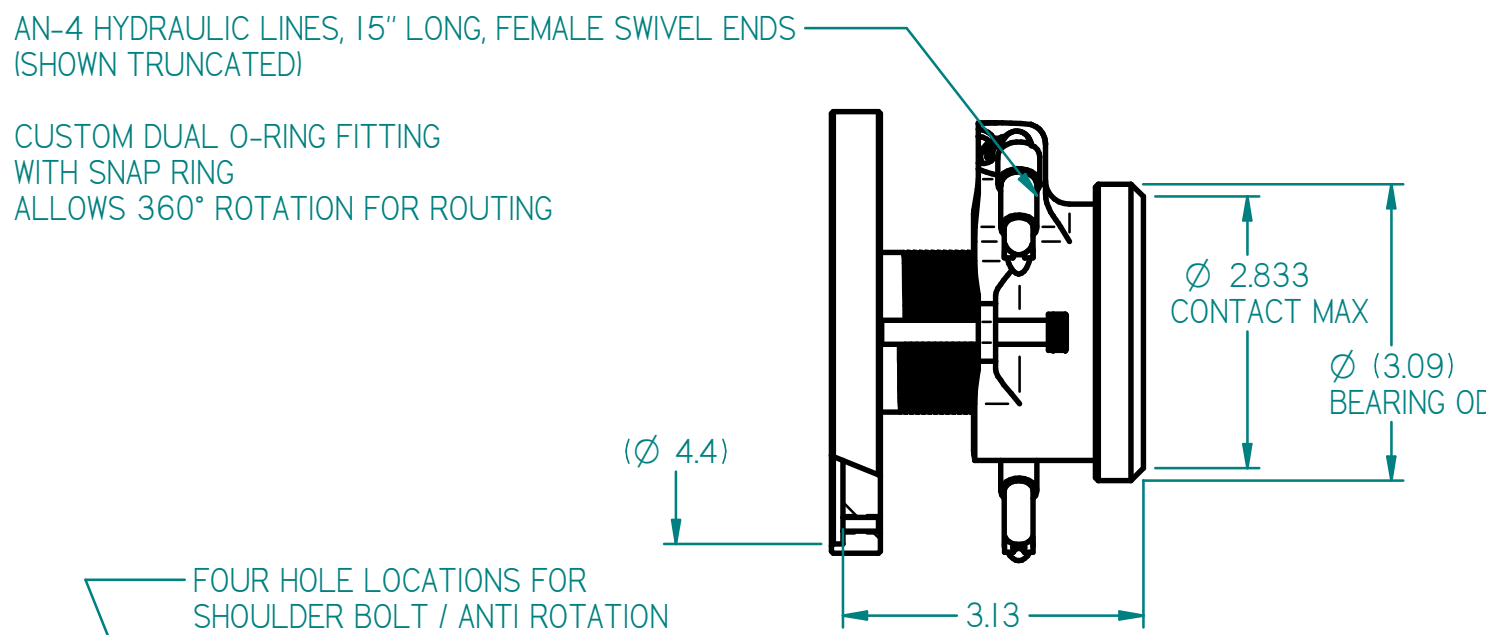

ITEM #	PART #	DESCRIPTION	QTY
1	62-899	ASSY,ADAPTER,T56 CHEV/FORD/MOPAR, 6000 SERIES HRB	1
2	60-610	HYDR REL BRG, FLAT FACE	1
4	1/4 X 1 3/4 SB	SHOULDER BOLT	1

**TILTON ENGINEERING, INC.** FAX 805/688-2745  
 25 EASY STREET, P.O. BOX 1787, BUELLTON, CA 93427 805/688-2353

**TITLE: FLAT FACE HYDRAULIC RELEASE BEARING ASSEMBLY  
 ADJUSTABLE HEIGHT, MAXIMUM / MINIMUM**

DRAWN BY <b>LUND</b>	CHKD <b>WAHL</b>	SCALE <b>1:1</b>	SIZE <b>B</b>	DWG <b>6294</b>	REV <b>A</b>
P/N <b>SEE TABLES</b>	DATE <b>12/14/2015</b>	SHEET <b>1 OF 1</b>			

This document contains proprietary information of TILTON ENGINEERING, INC., and its receipt or possession does not convey the rights to reproduce, disclose its contents, or to manufacture, use or sell anything it may describe. Reproduction, disclosure, or use without specific written authorization of TILTON ENGINEERING, INC. is strictly forbidden.

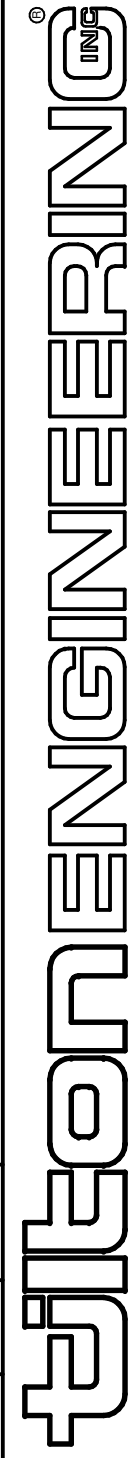

REV	ECN	DATE	BY	CHANGE OR ADDITION
-----	-----	------	----	--------------------

AN-4 HYDRAULIC LINES, 15" LONG, FEMALE SWIVEL ENDS (SHOWN TRUNCATED)

CUSTOM DUAL O-RING FITTING WITH SNAP RING  
ALLOWS 360° ROTATION FOR ROUTING

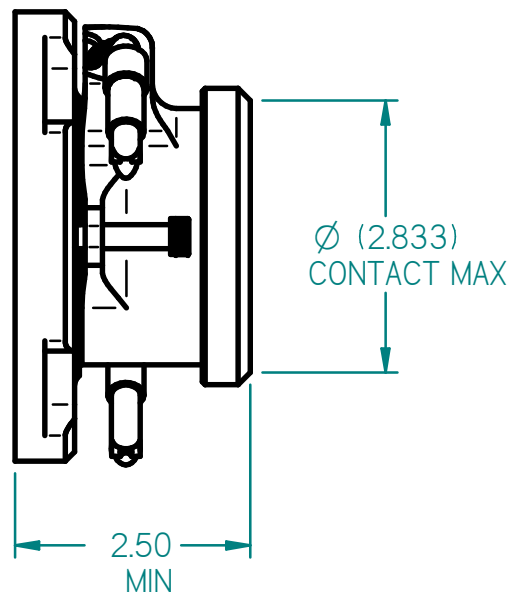
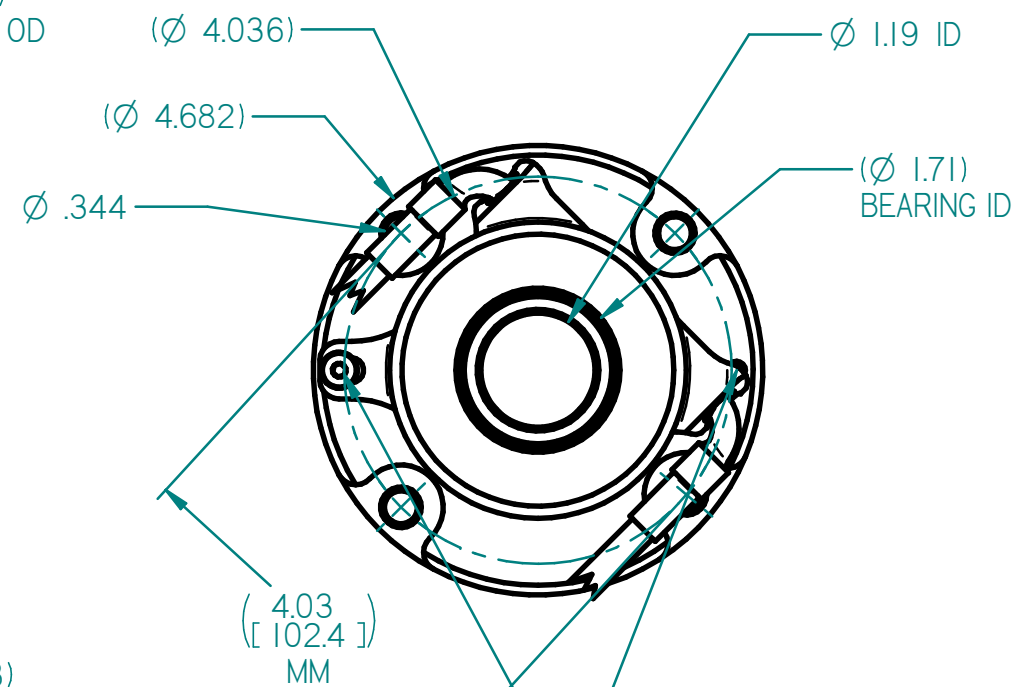
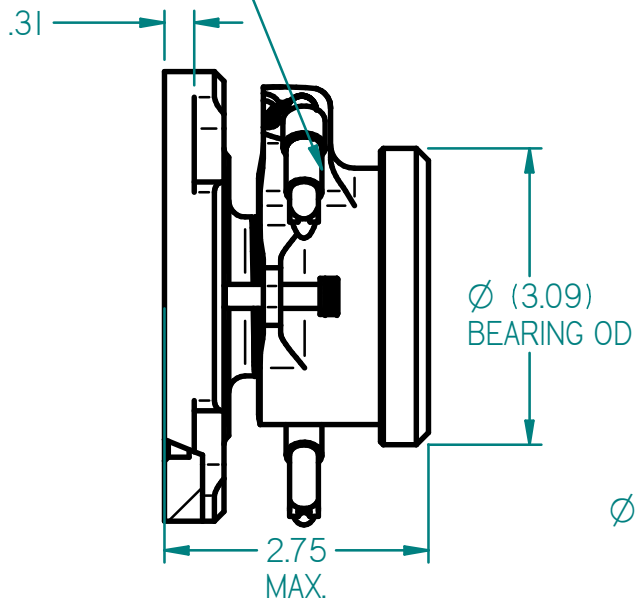
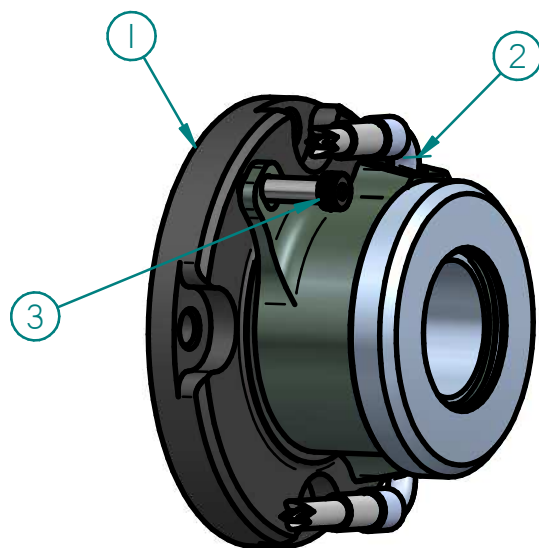

TWO HOLE LOCATIONS FOR SHOULDER BOLT / ANTI ROTATION  
ALLOWS FOR FINE ADJUSTMENT OF OVERALL HEIGHT

ITEM #	PART #	DESCRIPTION	QTY
1	62-693	RETAINER ASSEMBLY, GM, TREMEC, 6000 SERIES	1
2	60-610	HYDR REL BRG, FLAT FACE	1
3	1/4 X 1.0 SB	SHOULDER BOLT	1

**NOTES:**

1. DIMENSIONS AND TOLERANCES PER ASME Y14.5 - 2009
2. UNLESS OTHERWISE SPECIFIED, ALL DIMENSIONS ARE IN INCHES.
3. SHOULDER BOLT IS INCLUDED WITH 62-893 ASSEMBLY.
4. USE ONLY WITH DOT-3 OR DOT-4 BRAKE FLUID.
5. NO INTERNAL TRAVEL LIMITER. MUST BE USED WITH CLUTCH PEDAL STOP.
6. SEAL REBUILD KIT = 62-905.
7. SEAL INSTALLATION TOOL = 96-002.
8. HYDRAULIC AREA = 1.215 SQ IN.
9. EITHER PORT MAY BE USED FOR FEED OR BLEED.
10. ORIENTATE BLEED PORT TO WITHIN 10 DEGREES OF TOP CENTER TO FACILITATE BLEEDING PROCESS.

TILTON ENGINEERING, INC.		FAX 805/688-2745	
25 EASY STREET, P.O. BOX 1787, BUELLTON, CA 93427 805/688-2353			
<b>TITLE: FLAT FACE HYDRAULIC RELEASE BEARING ASSEMBLY ADJUSTABLE HEIGHT, MAXIMUM / MINIMUM</b>			
DRAWN BY LUND	CHKD WAHL	SCALE 1:1	SIZE DWG
P/N 60-6106	DATE 4/5/2016	SHEET 1 OF 1	B 6323
			REV B

This document contains proprietary information of TILTON ENGINEERING, INC., and its receipt or possession does not convey the rights to reproduce, disclose its contents, or to manufacture, use or sell anything it may describe. Reproduction, disclosure, or use without specific written authorization of TILTON ENGINEERING INC. is strictly forbidden.

