

INSTALLATION NOTES:

1. USE ONLY WITH DOT-3 OR DOT-4 BRAKE FLUID.
2. NO INTERNAL TRAVEL LIMITER. MUST BE USED WITH CLUTCH PEDAL STOP.
3. SEAL REBUILD KIT = 62-905.
4. SEAL INSTALLATION TOOL = 96-002.
5. HYDRAULIC AREA = 1.215 SQ IN.
6. EITHER PORT MAY BE USED FOR FEED OR BLEED.
7. ORIENTATE BLEED PORT TO WITHIN 10 DEGREES OF TOP CENTER TO FACILITATE BLEEDING PROCESS.
8. UNIT IS SHIPPED WITH 62-903 SHIM (.050" THICK) INSTALLED UNDER THE BEARING WHICH MAY BE REMOVED FOR ADDITIONAL CLEARANCE.
9. BOTH PORTS 3/8-24 UNF X .28 THREAD DEPTH.

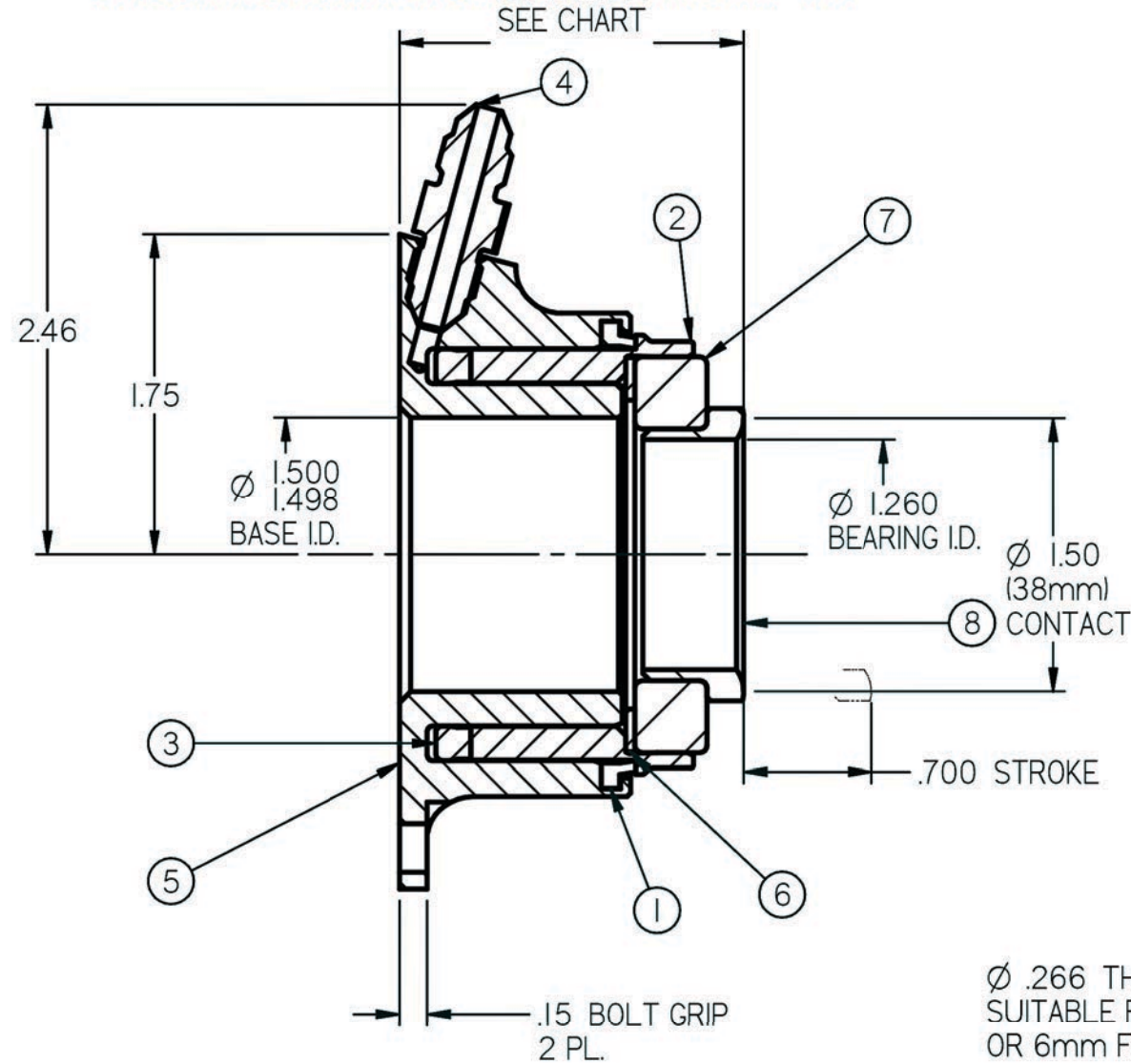

SECTION A-A

Item	PART NUMBER	DESCRIPTION	QTY
1	62-617	WIPER	1
2	SEE CHART	PISTON	1
3	62-614	HYDRAULIC SEAL	1
4	73-820	FITTING, AN-3	2
5	62-806	HYDRAULIC BASE	1
6	62-903	SHIM	1
7	62-008	BEARING	1

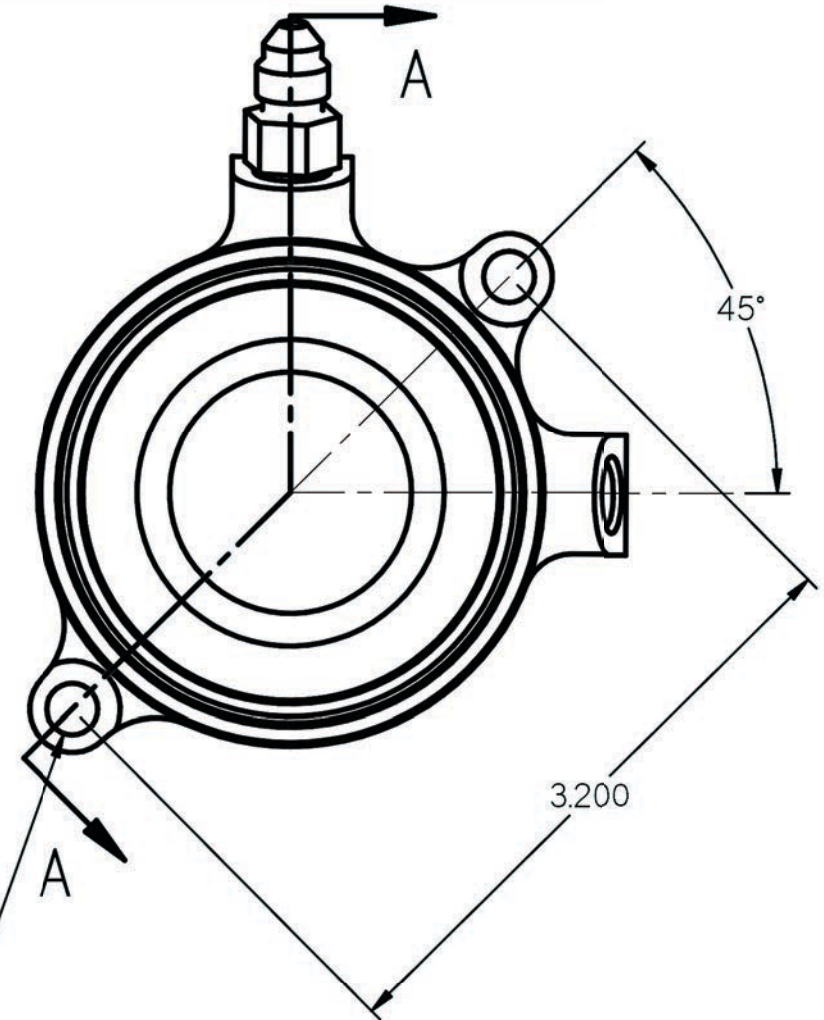

CHART OF AVAILABLE ASSEMBLIES		
HEIGHT	ASSY PN	PISTON PN
1.82"-1.87"	60-8300	62-6000
1.92"-1.97"	60-8310	62-6001
2.02"-2.07"	60-8320	62-6002
2.12"-2.17"	60-8330	62-6003
2.22"-2.27"	60-8340	62-6004
2.32"-2.37"	60-8350	62-6005
2.42"-2.47"	60-8360	62-6006
2.52"-2.57"	60-8370	62-6007
2.62"-2.67"	60-8380	62-6008
2.72"-2.77"	60-8390	62-6009

*HEIGHTS SHOWN IN CHART ARE WITH AND WITHOUT 62-903 SHIM

TILTON ENGINEERING, INC.		FAX 805/688-2745	
25 EASY STREET, P.O. BOX 1787, BUELLTON, CA 93427 805/688-2353			
TITLE: HYDRAULIC RELEASE BEARING ASSEMBLY			
38 mm RADIUS FACED BEARING, UNIVERSAL BASE			
DRAWN BY WAHL	CHKD LUND	SCALE 1:1	SIZE DWG
P/N SEE CHART	DATE 03/20/2012	SHEET 1 OF 1	B 5610
			REV NC

This document contains proprietary information of TILTON ENGINEERING, INC., and its receipt or possession does not convey the rights to reproduce, disclose its contents, or to manufacture, use or sell anything it may describe. Reproduction, disclosure, or use without specific written authorization of TILTON ENGINEERING, INC. is strictly forbidden.

