

REV	ECN	DATE	BY	CHANGE OR ADDITION
B	1102	9/18/13	LUND	ADDED DUAL DIMENSIONS

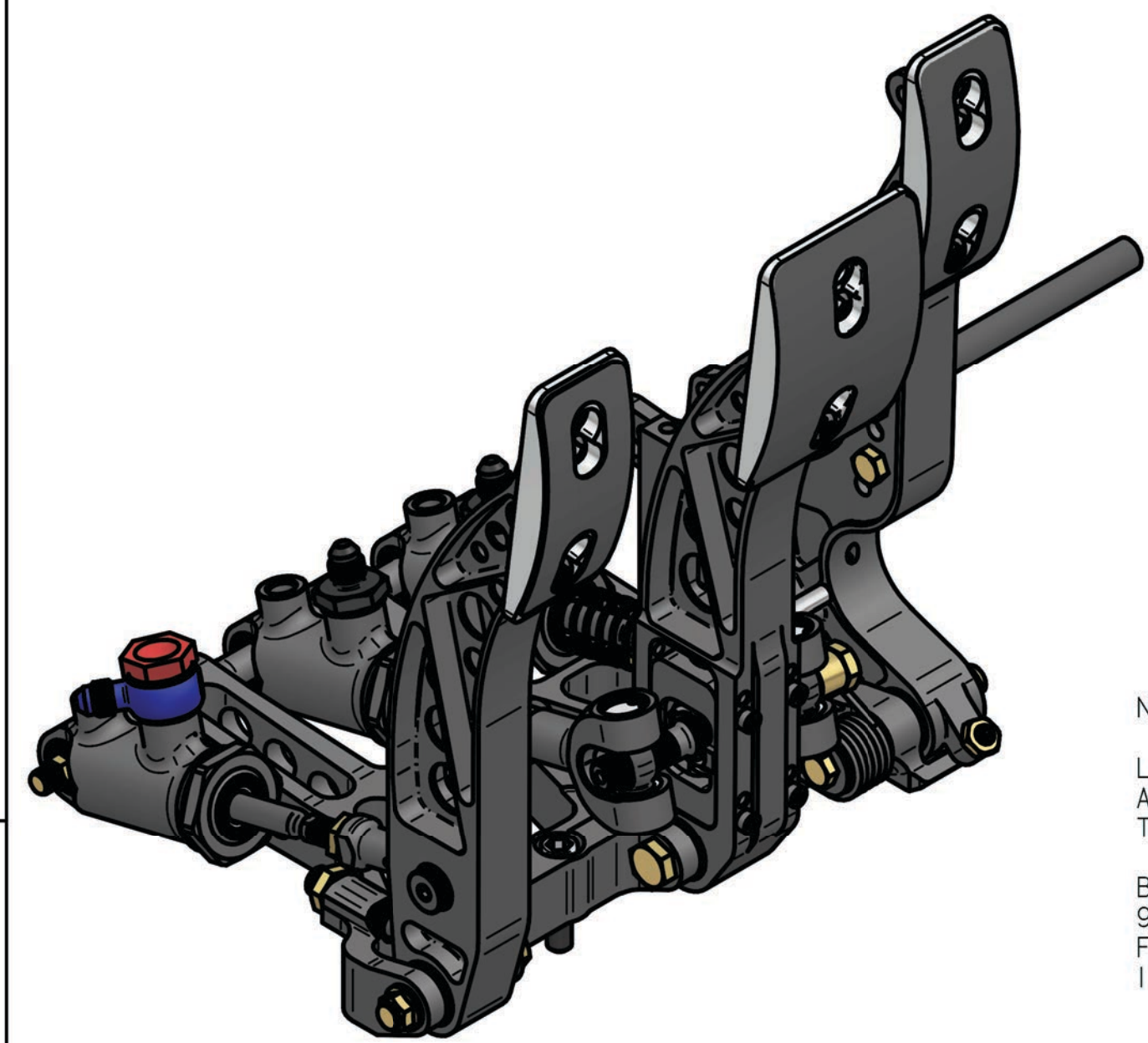

-4 AN MALE INLET BANJO
GOODRIDGE P/N 776-04-M14 FITTING
GOODRIDGE P/N 775-06 BANJO BOLT
GOODRIDGE P/N CW901-6 CRUSH WASHER (2 REQUIRED)
AVAILABLE FROM ANY GOODRIDGE DEALER

NEEDLE BEARINGS ON ALL BIAS BAR PIVOTS
LONG CLEVIS FOR LONGER STROKE FRONT MASTER CYLINDER
AT REST, LONG CLEVIS ROTATES BIAS BAR AS SHOWN.
THIS ALLOWS BIAS BAR TO RUN SQUARE UNDER BRAKING

BIAS BAR DATA:
9 TURNS OF TOTAL ADJUSTMENT
FRONT TO REAR BIAS FROM 59/41% TO 41/59%
1 TURN = 1.9% CHANGE

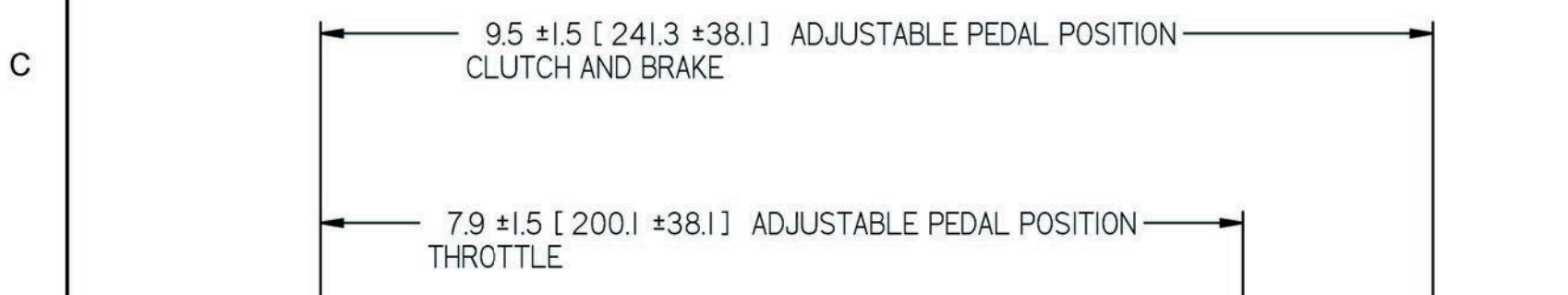
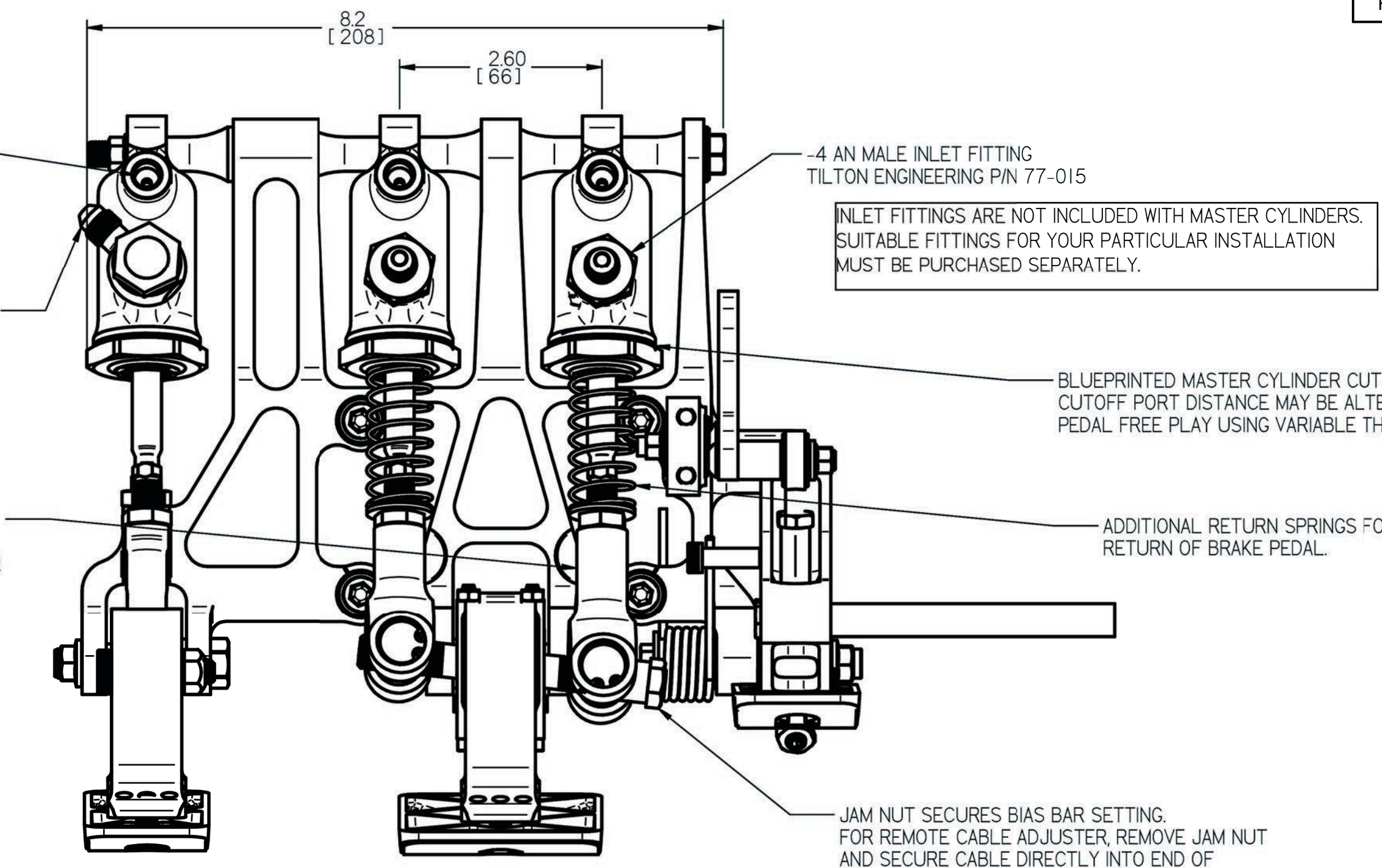

ALL 3 PEDALS, .580 TOTAL
FOOT PAD SIDE ADJUSTMENT
THREE POSITIONS, .290 INCREMENTS

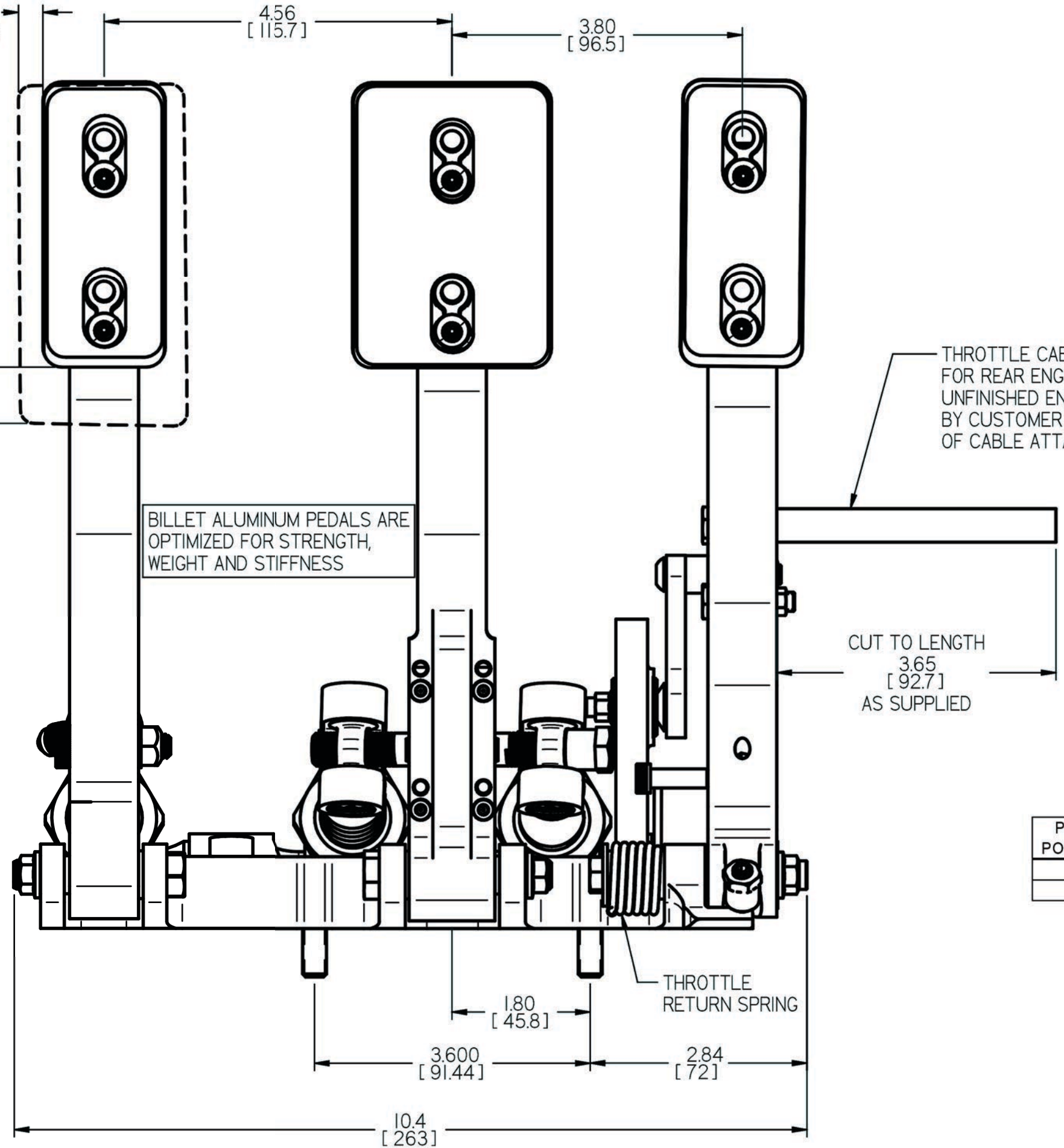

2 POSITION ADJUSTABLE PEDAL RATIO.

PIVOT POSITION	FOOT PAD POSITION			
	low	med-low	med-hi	high
H	4.52	4.65	4.78	4.91
L	5.32	5.48	5.63	5.80

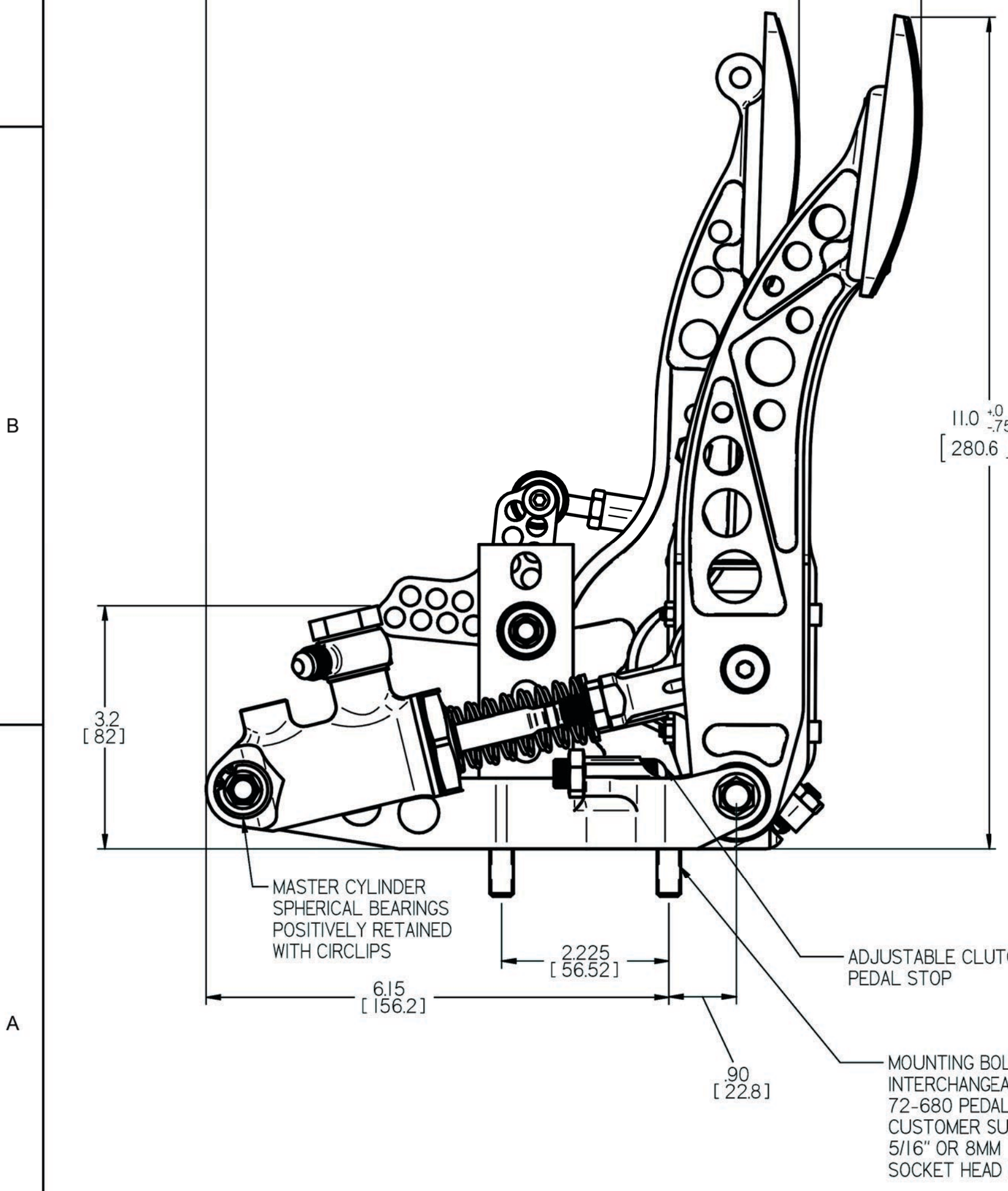

5 THROTTLE STANDOFF
OR BELL-CRANK LINKAGE
MOUNTING POSITIONS

OPTIONAL BELL-CRANK THROTTLE
LINKAGE ASSEMBLY P/N 72-791
FOR FRONT ENGINE CARS.
FULLY ADJUSTABLE FOR TOTAL THROW
AND PROGRESSION

77 SERIES MASTER CYLINDER
SOLD SEPARATELY
5/8" TO 1" BORE AVAILABLE

NOTES:
1. UNLESS OTHERWISE SPECIFIED, ALL DIMENSIONS ARE INCHES [MM].
2. DIMENSIONS ARE NOMINAL
3. WEIGHT 5.00 LB, AS SUPPLIED. NO MASTER CYLINDERS, NO 72-791 LINKAGE

TILTON ENGINEERING, INC.		(805) 688-2353 FAX (805) 688-2745	
25 EASY STREET P.O. BOX 1787		BUELLTON, CALIFORNIA 93427 USA	
TITLE: CUSTOMER INSTALLATION DRAWING FLOOR MOUNT PIVOT MOUNT PEDAL ASSEMBLY			
DRN BY VANSCHMUS	CHKD	SCALE .75	DWG 4955
P/N 72-903	DATE 06/25/05	SHEET 1 OF 1	REV B

"This document contains proprietary information of TILTON ENGINEERING, INC., and its receipt or possession does not convey the rights to reproduce, disclose its contents, or to manufacture, use or sell anything it may describe. Reproduction, disclosure, or use without specific written authorization of TILTON ENGINEERING, INC. is strictly forbidden."

TILTON ENGINEERING INC.